

General Tolerances/Allg.Toleranzen DIN

ISO2768-mk

$0.5 \leq 3$	$>3 \leq 6$	$>6 \leq 30$	$>30 \leq 120$	$>120 \leq 400$
± 0.1	± 0.1	± 0.2	± 0.3	± 0.5

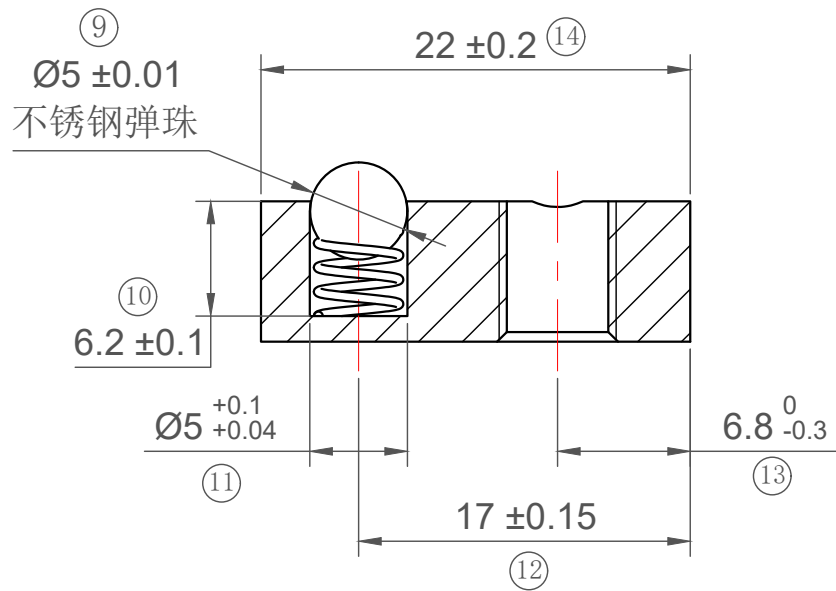
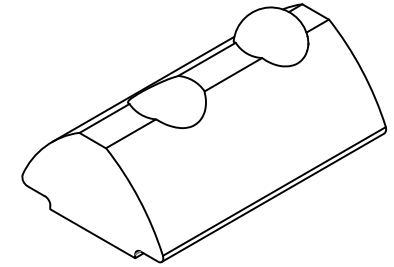
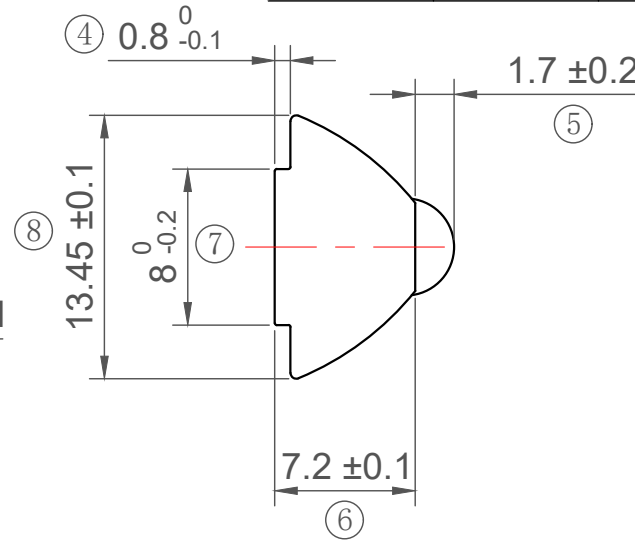
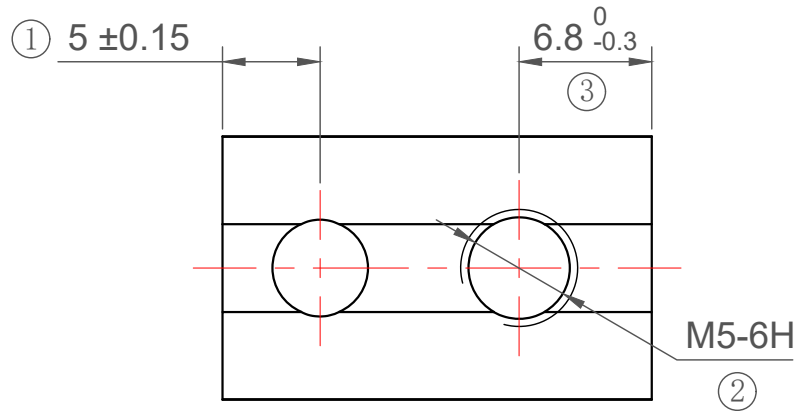

1. Material: Carbon Steel;

2. Surface treatment: Zinc Plated;

3. Appearance should be without lack materials, smudge and burs;

4. Unspecified length tolerance according to 2768-M intermediate tolerance